

User Manual

Introduction

SOBOWO E-bike

Welcome

Thank you for purchasing an e-bike from SOBOWO™. We take pride in bringing you a quality product that will offer you years of enjoyment.

SOBOWO™ e-bikes are featured with, zero emission, battery powered, with stable performance and overall after-service. The SOBOWO™ e-bike contains a safe and fun environment for the rider and surrounding environment and use area.

Using this Manual

This manual contains details of the product, its equipment, and information on its operation and maintenance. Read it carefully and familiarize yourself with the e-bike before using it in order to ensure safe use and prevent tragic accidents. Be sure to retain this manual as reference to product knowledge and safe riding.

The manual includes many Warnings and Cautions concerning the safe operation and consequences if safe operation is not performed in respect to operation and maintenance of this product. All information in the manual should be carefully studied and if you have any questions, you should contact SOBOWO™ Company immediately. The notes/warnings/cautions included within the dotted red boxes as shown to the left should be given special care when reviewing as they are directly related to hazardous or dangerous situations if not avoided.

Because it is impossible to anticipate every situation or condition which can occur while riding, this manual makes no representation about the safe use of the bicycle under all conditions. There are risks associated with the use of and bicycle which cannot be predicted or avoided, and which are the sole responsibility of the rider. You should save this manual, along with any other documents that were included with your bicycle, for future reference. However, all content in this manual is subject to change or withdrawal without notice. SOBOWO™ Company makes every effort to ensure the accuracy of its documentation and assumes no responsibility or liability for any errors or inaccuracies that may appear herein.

Index	
Parts description-----	1
Daily checks-----	2
Assembling instructions -----	3
Battery charging-----	5
Additional charging Info-----	6
About charging-----	7
Driving-----	8
Driving range-----	10
Additional safely notes-----	11
Basic maintenance-----	13
Troubleshooting-----	14
Recommended torque values for threaded fasteners-----	15
Minimum saddle height and the way to measure-----	16
Wiring diagram with LCD display-----	17
Saving battery power and extending your range-----	18
Useful tips-----	21
General warning-----	22
A note for parents and guardians-----	23
Safety notes before first use-----	24
Additional safely notes-----	25

Parts description

SOBOWO E-bike



To ensure the safety make the following functional checks before driving:

- 1 - Normal operation of the light, brake and power cut system.
- 2 - Tire pressure (low pressure; will influence both autonomy and speed).
- 3 - Wheel axle tightening.
- 4 - Battery charging level.
- 5 - Braking system adjustment and free operation.



Assembly instructions

SOBOWO E-bike

1. Unscrew the screws with a 5 mm wrench.
2. Put the handlebar in the fixing slot.
3. Fix the handlebar in the slot with the fixing accessories.
4. Insert the screw into the hole and adjust the position of the handlebar, then tighten the screws.



Assembly instructions

SOBOWO E-bike

1. Carefully take out the electric bike from its carton;
2. Please tighten the handlebar-stem with the following instruction;
 - A. Use M5 Allen Key to tighten;
 - B. Press the rubber after tightening;



Charging tips

- The battery pack should be recharged after each use. There is no memory effect so you can charge the battery after short periods of use without damage.
- The battery can be recharged on or off the bike.
- Remove the battery by turning the key and then pulling forwards and upwards carefully until the pack lifts off.
- The charger will automatically stop once the battery pack is full.
- Always charge in dry conditions and indoors away from direct sunlight.
- Before you start charging, please check whether the charger cable, charger or battery are damaged.

With the battery removed

1. Do not touch the “+” and “-” contacts after removing the battery, especially wet hands or metal objects.
2. Do not recharge the battery in the inverted position. If you do, you drastically reducing its lifespan.
3. Place the charge in a flat, secure place, and connect the output plug to the socket in the battery box.
4. Then, connect the input plug(110V/220V terminal) to the power outlet, and the charging will start.
5. After the charging has finished, first, unplug the input plug(terminal 110V/220V), and then the output plug.

Additional Charging Info

SOBOWO E-bike

When the battery is charging on the bike

1. Switch off the power. The battery can be charged on or off the bike.
2. Plug the output lead of the charger into the socket of the battery case.
3. Plug the AC power input plug into the 110/220 volt household power socket to start charging.
4. After charging unplug from the wall outlet first and then from the bike charger socket.

NOTE: Always charge your battery at temperatures between 10 and 26 Celsius degrees and battery is not damaged before charging.



Duration of charging

1. When the input and output terminal are connected, the red indication light of the charger will be turned on, showing that the power is being connected.
2. When the battery is charged for the first time, 8-10 hours should be spent for charging. When the yellow indication light of the charger is turned on, showing that the battery basically full and it will switch to trickle charge mode to ensure that over-charging will not occur, it takes 2-8 hours for normal charging.
3. This charger has the protection device for over-charging. Long time charging should not be more than 24 hours without affecting the lifetime of the battery.

If charging with the battery removed

- 1- Keep the charger in a safe place, away from children.
- 2-Do not use the battery when not fully charged. That will decrease its lifespan.
- 3-Do not charge the battery with other charger than the original.
- 4-The charger works with 110/220V. Please do not open it without permission.
- 5-Avoid charger contact with liquids and/or metal objects. Always be sure it is safely stored/placed so that it cannot suffer damage from a fall/impact.
- 6-When in use, the charger should not be covered, to prevent overheating, damage, or fire.
- 7-The charger is only for indoor use. Please keep it in dry and ventilated place.
- 8-If you notice a strange smell from the charger, or it is too hot, stop charging, and please contact **SOBOWO™**.

Important tips while driving

- 1-In order to reduce consumption, increase autonomy, and extend the motors lifespan, use the pedals during the start-up and climbs.
- 2-Do not twist the throttle too fast. The vehicle should be accelerated slowly, reducing consumption and risk of damage to the electrical system. It is better to use the pedals to avoid sudden stops and start-up.
- 3-To increase security and reduce power consumption, it is advised to avoid sudden stops and start-up.
- 4-The vehicle controller has a charge overload protection. If on overload, energy will be cut automatically and restored when it returns to normal.
- 5-While driving, avoid using the throttle as you brake, as it may damage the motor.
- 6-The maximum load is 100-120KGs. Avoid driving with overload. Do not drive too fast.

Important tips when parking

- 1-When pushing the vehicle manually, turn off the power, to avoid accidental acceleration and accidents.
- 2-It is recommended to park indoors. Do not forget to switch off the power and remove the key.
- 3-In a public place, the e-bike must be parked in accordance with local traffic rules. Do not forget to switch off the power and remove the key.

How to start up the vehicle

A.

Press the battery ON/OFF button and battery power LED display to see the power capacity.



B.



-Hold down center button on button cluster until LCD screen turns on.



Option: Please check the LCD Display manual for details.

Driving Range

SOBOWO E-bike

Average distance from one charge: 25-40km (active state) differs from different batteries.
 Conditions of testing: wind speed: level 2-3, normal atmosphere temperature: 25 degrees,
 Load: 90kg, atmospheric pressure: 3.5kg/cm, flat concrete surface; battery: full

Surfa \ Rang	10Km	20Km	30Km	40Km	Driving condition
Flat					Wind level:2-3 Normal temperature:25°C Normal load
Flat					against wind level:2-3 Normal temperature:25°C normal load
upslope/downsl					degree of slope ≤ 2 degree wind level: 2-3 normal temperature: 25°C normal load

Max speed (25Kmh) miles of journey

Power consumption of one time charge: ≤ 0.5 kw.h

Economical speed: 18km/s

The load haul is related to road, road surface, times of start-up, times of braking, wind direction, atmospheric temperature, air pressure in the tire and correct way of charging, please note this during driving.

Economy speed (10km/s) miles of journey

Rated load: 90kg

Dead load: ≤ 30 kg

A.

Specific operation explanations



1.1 Change PAS grade

Suppose it is PAS mode now,

shortly press , PAS grade -1

shortly press , PAS grade +1

1.2 Shift the speed display

Long press  + , to shift the way of speed display

1.3 ON/OFF 6KM/H cruising, ON/OFF

Headlight, Reset ODO

When e-bike stops, long press 

to enter 6KM/H cruising mode. Stop pressing to exit the cruise mode;

Long press  to turn ON/OFF Headlight;

At P16, long press  for 5s to reset ODO.

1.4 ON/OFF the screen

Long press  to turn ON/OFF the screen.



1.5 Change data in multi-function Area



Shortly press  to change data.

Additional Safety Notes

SOBOWO E-bike

1.6 Parameters setting



Long press  +  to start setting parameters, such as wheel size(inch), background luminance...
(Refer to P01-P16)

On the setting interface, shortly press  , or  to plus/minus value. Parameters would be shining after modifying, choose the ones you prefer,

a.Long press  to save the value, the shining would stop.

b.Shortly press  to shift to the next parameter, and to save current values.

c.at the same time.

d.Press  +  to exit setting parameters and to save values. If not press these buttons, it would exit and save parameters modified automatically 10s later.

To ensure safe riding conditions you must properly maintain your bike. You should follow the basic guidelines below and see your certified local bike shop seasonally to ensure your bike is safe for using.

Regular self-checks

1. Tightening and correct operation of both wheels, frame and front fork.
2. Tire pressure and conditions.
3. Gearshift correct operation.
4. Bell and reflectors conditions and correct operation.
5. Braking system correct operation.
6. If you do not use the vehicle for long periods of time, charge the battery at least once a month, To avoid reducing its lifespan.

Maintenance and cleaning tips

1. Do not wash with high-pressure jets to prevent water infiltration into the electrical system.
2. Dirt on painted surfaces should be removed with a neutral product. Then, wipe with a dry cloth.
3. Lubricate the vehicle with suitable lubricant, after washing.
4. Do not apply lubricant on the brakes, brake levers, rims, tires, battery and controller.

Troubleshooting

SOBOWO E-bike

	Symptoms	Possible causes	Most common solutions
1	It doesn't work	(1)Insufficient battery power (2)Faulty connections (3)Key in wrong position	(1)Charge the battery (2)Clean the connections (3)Turn the key into the correct position
2	Irregular acceleration and/or reduced top speed	(1)Insufficient battery power (2)Loose throttle magneto (3)Damaged throttle spring	(1)Charge the battery (2)Weld and adjust (3>Contact an Authorized Service Center
3	When powered on, the motor doesn't respond	(1)Loose wiring (2)Loose throttle magneto (3)Motor wiring plug is loose or damaged	(1)Repair and/or reconnect (2)Weld and adjust (3>Contact an Authorized Service Center
4	Reduced range	(1)Low tire pressure (2)Low or faulty battery charge (3)Driving with too many hills, braking, departures, and/or excessive load (4)Battery discharged for long period of time, without regular charges, aged or damaged	(1)Adjust the tire pressure (2)Check the connections and/or fully charge the battery (3)Help with the pedals (4)Replace the battery (5)Make a prolonged battery charge
5	The battery won't charge	(1)Charger not well connected (2)Battery cases fuse blown (3)Battery wiring disconnected or with a bad contact	(1)Adjust the connections (2)Replace the fuse (3)Reconnect/repair the wiring
6	Driving wheel makes strange noises	(1)Charger not well connected (2)Battery cases fuse blown	(1)Replace the bearing (2)Adjust/replace the rim

For your safety, do regular maintenance and tightening checks. If you find any abnormality, repair immediately.

Recommended torque values for threaded fasteners

SOBOWO E-bike

NO.	Parts	Torque required(N.M)
1	Handlebar	18-20
2	Handlebar-stem	18-20
3	Saddle	18-20
4	Seat-pillar	18-20
5	Front wheel	16-25
6	Rear Wheel	25-35
7	B.B Parts	35-55

Minimum saddle height and the way to measure

SOBOWO E-bike



To adjust seat height, use quick release lever to free the seat post and pull upwards or push downwards to reach desired height.

Wiring diagram with LCD display

SOBOWO E-bike

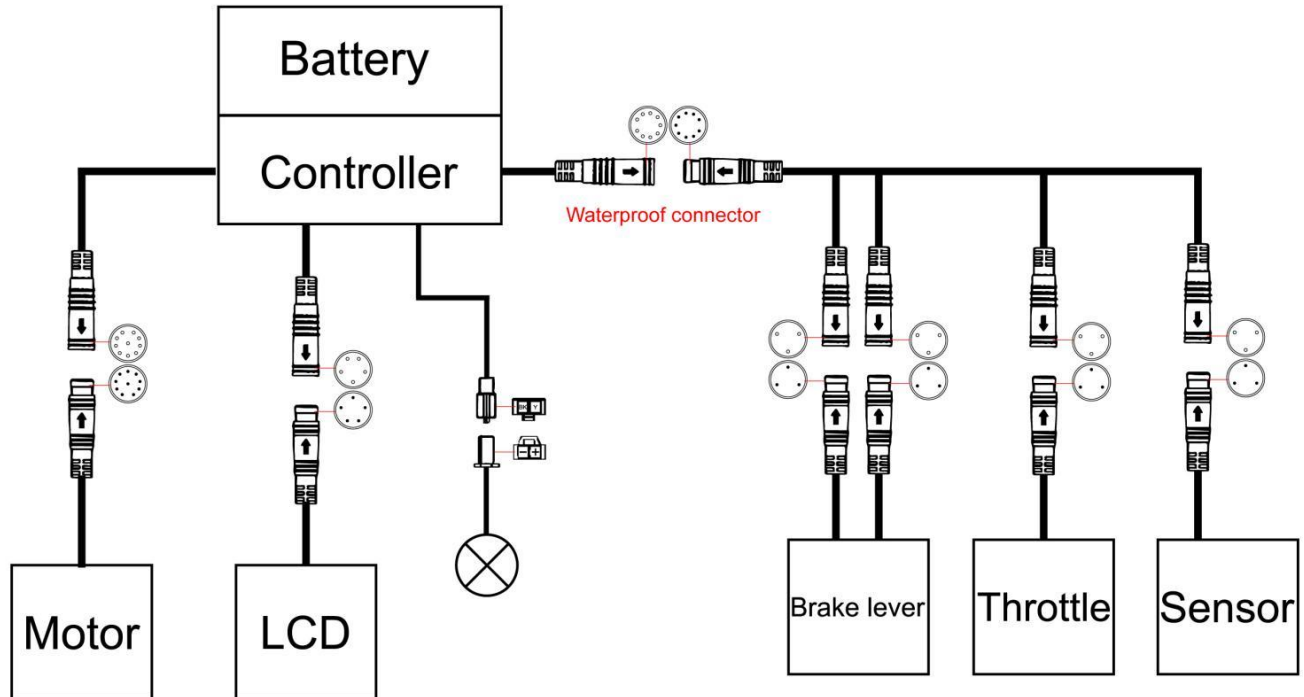

Remark:

1: Except label wire diameter, other = 0.30mm². 2: All connector terminal is electrolytic tinning.

3: All wires are national standard wires.

R=red, B=blue, Bk=black, G=green, Y=yellow, Pr=purple, W=white, Pink=pink, O=orange, Cam blue=cam bridge blue

Saving battery power and extending your range

SOBOWO E-bike

Frequent braking and starting, riding uphill against a strong wind, starting from a standstill and riding on rough or muddy roads, and carrying more than one person, or heavy loads will consume extra battery power and shorten the range.

A few tips to prolong the battery life.

1. Avoid frequent Braking - try to look ahead and coast rather than stop and go frequently.
2. Ride downhill or use hard air pedals to replenish battery power.
3. When starting from a standstill-use the pedals to help bring you up to speed.
4. When the battery meter indicators the voltage is low, switch to manual power and avoid using the battery so you don't shorten the battery life.
5. If the battery is being stored, remove the battery from the bicycle and recharge it every month.

Steep Hills and Hub Motors

SOBOWO E-bike

This electric cargo bike uses a brushless hub motor which provides efficient performance in many types of riding conditions. Hub motors are designed to provide years of trouble free use, however if not taken care of, they can be damaged by overloading. Be sure to pedal with your cargo e-bike when climbing steep hills and ensure the wattage/power consumption is kept below 250 watts continuously on long climbs. In hilly terrain, it is recommended that users always pedal to assist the bike in climbing up hills. This can be accomplished by setting the pedal assist level to “Level 1 or Level 2” or riding with the twist throttle only partially applied. Watch the watt meter on the display and ensure that you regulate the power output of the motor so that it stays below 250 watts continuously on steep hills. Never ride up hills which exceed a 15 percent (%) slope with the motor fully engaged. If you want to ride up hills steeper than 15% slope, first set the pedal assist level to “level 0, level 1, or level 2” to avoid exceeding 250W of power to the motor.

Maintenance

SOBOWO E-bike

Cleaning: Pressure washers or hosing down of the cargo e-bike voids the warranty. The cargo e-bike should only be cleaned with a moist rag and non-corrosive biodegradable cleaners.

Yearly maintenance checks: Your cargo e-bike should be given a full tune-up by a professional bicycle mechanic on a yearly basis.

Brake pads: Electric bikes travel at higher speeds and have more momentum because of the weight of the powered components, for this reason brake pads normally wear down faster than a traditional non-powered bike. Users must check brake pads regularly and replace whenever worn.

1. This user manual should be used only to reference use and functions but should not be used as a reference for inspection.
2. The images shown may differ from the actual model to technical improvements.
3. We reserve the right to change the model without prior notice due to technical improvements.
4. The vehicle has a top speed limiter. For safety purposes, its removal is strictly prohibited.
5. Ensure pre-record checks are performed before each and every ride.
6. Only allow others to ride who have already been adequacy trained on the use and operation of this product

General Warning

SOBOWO E-bike

Like and sport, bicycling involves risk of injury and damage. By choosing to ride a bicycle, you assume the responsibility for that risk, so you need to know—and to practice—the rules of safe and responsible riding and of proper use and maintenance. Proper use and maintenance of your bicycle reduces risk of injury.

Your bicycle is designed for use by persons 16 years old and above. Riders must have the physical coordination, reaction time and mental capability to ride and manage traffic, road conditions, sudden situations and also respect the laws governing bicycle use where they ride, regardless of age.

If you have an impairment or disability such as a visual impairment, hearing impairment, physical impairment, cognitive/language impairment, or a seizure disorder, consult your physician before riding any bicycle.

Note on Helmets

Make sure that you always wears an approved bicycle helmet when riding; but also make sure that you understands that a bicycle helmet is for bicycling only, and must be removed when not riding. A helmet must not be worn while playing, in play areas, on playground equipment, while climbing trees, or at any time while not riding a bicycle. Failure to follow this warning could result in serious injury or death. Do not let a child younger than 16 years old ride the bicycle.

Additional Noted for parents

As a parent or guardian, you are responsible for the activities and safety of your child, and that included making sure that the bicycle is properly fitted to the child; that it is in good repair and safe operating condition; that you and your child have learned and understand the safe operation of the bicycle; and that you and your child have learned, understand and obey not only the applicable local motor vehicle, bicycle and traffic laws, but also the common sense rules of safe and responsible bicycling. As a parent, you should read this manual, as well as review its warnings and the bicycle's functions and operating procedures

Safety notes before first use

SOBOWO E-bike

- Your bicycle comes with additional documents and manuals the manufacturers of the system components. These documents must also be read before using this product.
- All users must read this manual before first use.
- Ensure that you comprehend with all instruction and safety notes.
- Ensure the bikes fits you properly before first use. You may lose control or fall if your bike is too big or too small.
- Always wear an approved bicycle helmet while using this product and ensure that the helmet manufacturer's instructions for fit and care followed.
- Ensure correct tightening and setup is performed on your bicycle before first use and checked regularly.
- It is your responsibility to familiarize yourself with laws and requirements for the operation of this product in the area(s) where you ride.

Additional Safety Notes

SOBOWO E-bike

- Ensure handle bar grips are not damaged and improperly installed. Loose or damaged grips can cause you to lose control and fall.
- Failure to wear a helmet when riding may result in serious injury or death.
- Do not use this product with standard bicycle trailers, stands, or vehicle bicycle racks. Contact SOBOWO™ E-bike Company to check if your equipment will work with the bicycle.
- Off-road riding requires close attention and specific skills and present variable conditions and hazards that accompany the conditions. Wear appropriate safety gear and do not ride alone in remote areas.
- Take extra care while riding in wet conditions. Feet or hands can slip in wet conditions and lead to death or serious injury from a fall.
- Do not remove front or rear reflectors or the handlebar bell.
- Lights should and must be used in addition to reflectors in most locations.

Additional Safety Notes

SOBOWO E-bike

- Engaging in extreme riding is extremely dangerous and should be avoided. Although many articles/advertisements/catalogue depict riders in extreme terrain this not recommended nor permitted and you can be seriously injured or killed if you perform extreme riding.
- Bicycles and bicycle parts have strength and integrity limitations and extreme riding should not be performed or you risk damaging the components or becoming seriously injured or killed.
- Failure to confirm proper installation, comparability, proper operation, or maintenance of any component or accessory can result in serious injury or death.
- After any incident you must consider your bike unsafe to ride until you consult with a certified bicycle service provider for a comprehensive inspection.
- Failure to properly charge, store, or use your battery will void the warranty and may cause a hazardous situation.
- Extreme care should be taken when using the pedal assistance sensor on this product. Ensure you understand and are prepared for the power assistance to prepare you as soon as pedaling is underway.

Additional Safety Notes

SOBOWO E-bike

- You should check the operation of the brake inhibitor switches before each ride. The brake system is equipped with an inhibitor, which shuts down power to the electric motor whenever the brakes are engaged. Check proper operation slowly while in a controlled environment by riding slowly with the motor engaged and applying the brake levers are engaged.
- User must understand the operation of the twist throttle and pedal assist sensors before using, and take care in their usage in respect to traveling at speeds appropriate for usage area and user experience level. Always use the lowest assist level until you are comfortable with the bike and feel confident in controlling the power.
- Any changes to the product not expressly approved by SOBOWO™ E-Bike Company could void warranty and care while riding.
- Because electric bikes are heavier and faster than normal bicycles, they require extra caution and care while riding.
- To avoid shock never submerge the electrical components in water or subject to salt-water environments.

User Manual
